

# **\*\* WARNING \*\***

**All Dimensions Are Approximate.**

**Always Start By Anchoring the Power Unit Side leg. Then Use Floor Plate or Overhead Beam Too Locate The Second Leg Properly.**

**Never Drill Anchor Holes Without Legs In Place.**

**NTO-15 and NTO-20**

**\*\* CAUTION \*\***

**Never Start Lift Motor When  
The Pump Is Under A Load.**

**Always Start Lift Motor From Ground Position  
Or From Lift Locks.**

**Failure To Do This Can Burn Up Lift Motor  
And Void Motor Warranty.**

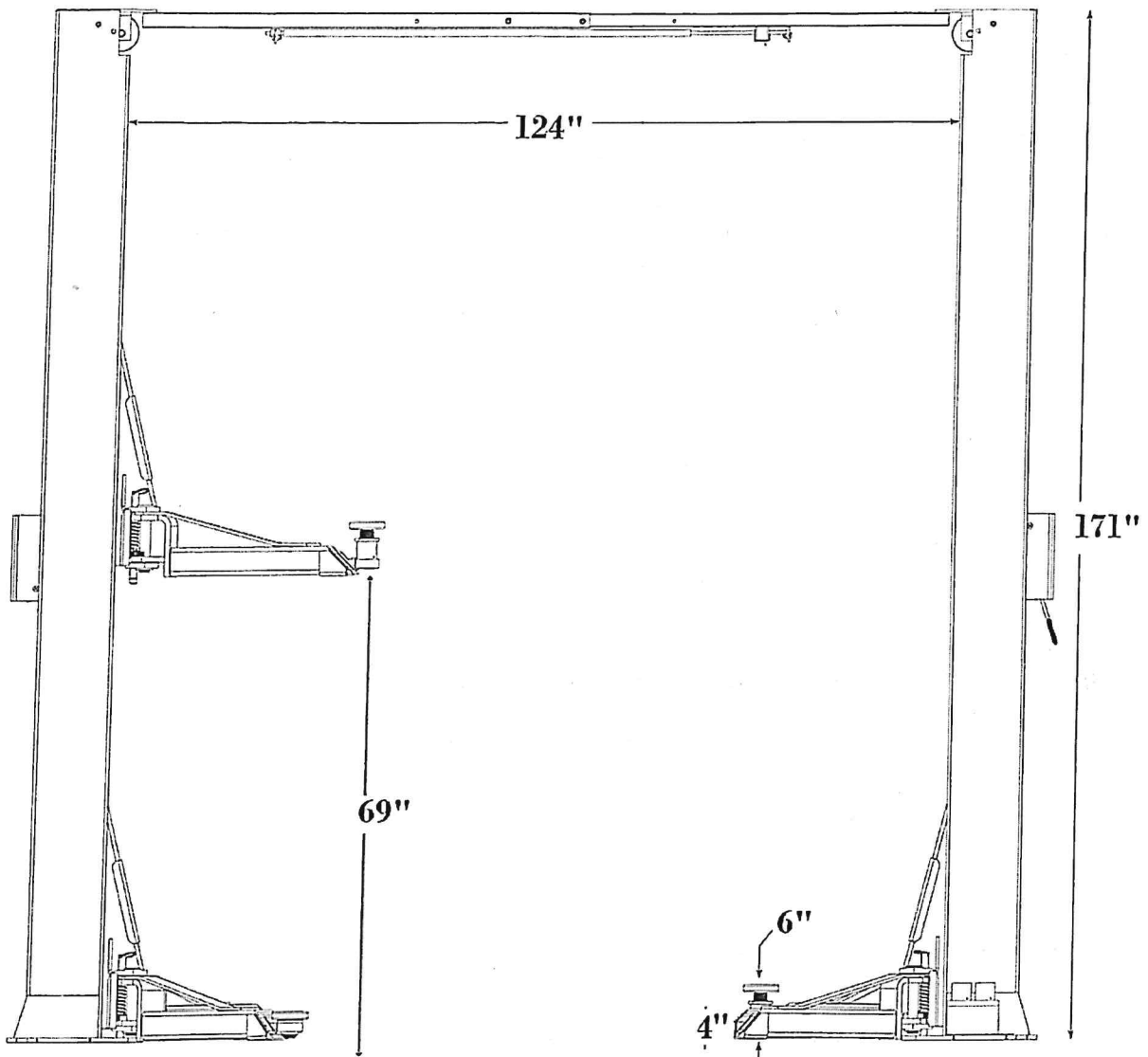

# NTO 20

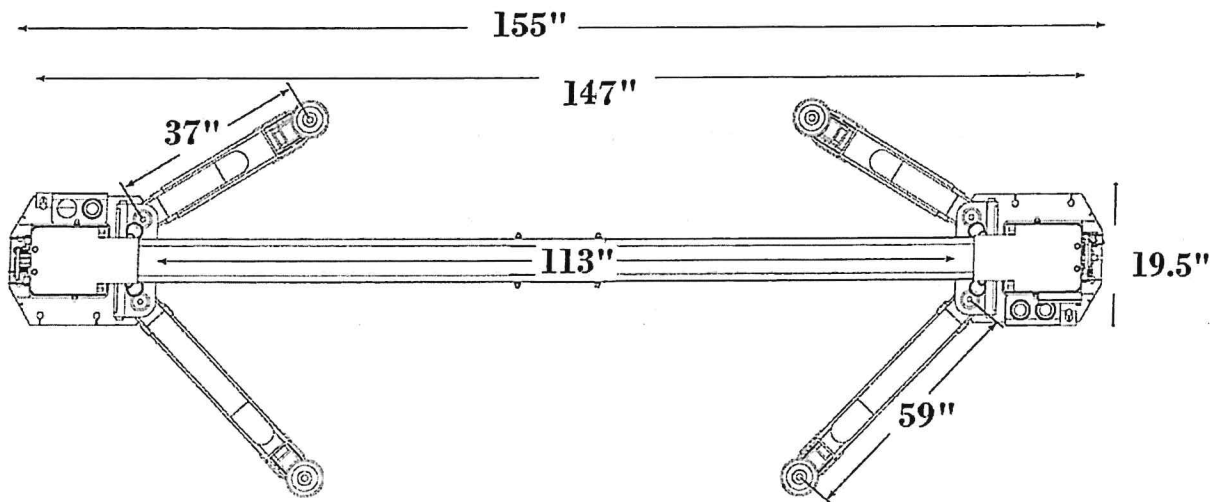

## SHIPPING AND DAMAGE CLAIMS

When this equipment is shipped, title passes to the purchaser upon receipt from the carrier. Consequently, claims for the material damaged in shipment must be made by the purchaser against the transportation company at the time shipment is received.

### BE SAFE

Your new lift was designed and built with safety in mind. However, your own safety can be increased by proper training and thoughtful operation on the part of the operator. **DO NOT** operate or repair this equipment without reading this manual and the important safety instructions shown inside.

Keep this operation manual near the machine at all times. Make sure that ALL USERS read this manual.

## READ THIS ENTIRE MANUAL BEFORE OPERATION BEGINS INTRODUCTION

1. Carefully remove crating and packing materials. **CAUTION!** Be careful when cutting steel banding material, as items may become loose and fall, causing personal harm or injury.
2. Inspect the lift for any signs of concealed shipment damage or shortages. Remember to report any shipping damage to the carrier and make a notation on the delivery receipt.
3. Check the voltage, phase and proper amperage requirements for the motor shown on the motor plate. Wiring should be performed by a certified electrician only.

## IMPORTANT SAFETY INSTRUCTIONS

### Read These Safety Instructions Thoroughly

1. Read and understand all safety warning procedures before operating lift.
2. Keep hands and feet clear. Remove hands and feet from any moving parts. Keep feet clear of lift when lowering. Avoid pinch points.
3. Keep work area clean. Cluttered work areas invite injuries.
4. Consider work area environment. Do not expose equipment to rain. Do not use in damp or wet locations. Keep area well lighted.
5. Only trained operators should operate this lift. All non-trained personnel should be kept away from work area. Never let non-trained personnel come in contact with, or operate lift.
6. Use lift correctly. Use lift in the proper manner. Never use lifting adapters other than those provided by the manufacturer.
7. Do not override self-closing controls.
8. Remain clear of lift when raising or lowering vehicle.
9. Clear area if vehicle is in danger of falling.
10. Always insure that the safeties are engaged before any attempt is made to work on or near vehicle.
11. Dress properly. Non-skid, steel-toe is recommended when operating lift.
12. Guard against electric shock. This lift must be grounded while in use to protect the operator from electric shock. Never connect the green power cord wire to a live terminal. This is for ground only.
13. **Danger!** The power unit used on this lift contains high voltage. Disconnect power at the receptacle before performing any electrical repairs. Secure plug so that it cannot be accidentally plugged in during service.
14. **Warning!** Risk of explosion. This equipment has internal arcing or sparking parts which should not be exposed to flammable vapors. This machine should not be located in a recessed area or below floor level.
15. Maintain with care. Keep lift clean for better and safe performance. Follow manual for proper lubrication and maintenance instructions. Keep control handles and/or buttons dry, clean and free from grease and oil.

- 16. Stay alert. Watch what you are doing. Use common sense. Be aware.
- 17. Check for damaged parts. Check for alignment of moving parts, breakage of parts or any condition that may affect its operation. Do not use lift if any component is broken or damaged.
- 18. Never remove safety related components from the lift. Do not use lift if safety related components are damaged or missing.

**PROFILE**

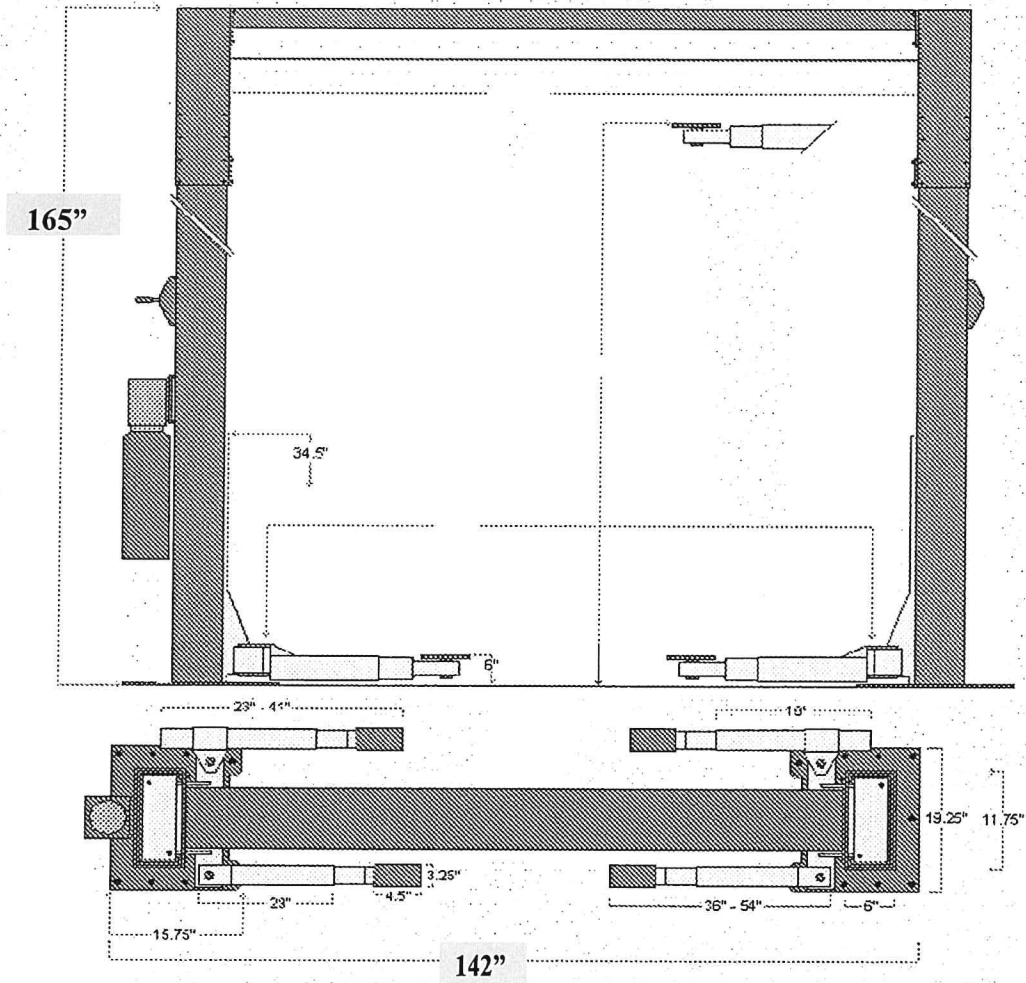

(fig. 1)

**BASIC INFORMATION**

Capacity	Max. Lift	Height	Width	Drive-through
15000lbs	72"	165"	142"	114"

**Voltage**

220v/30a/1ph

## BASIC INFORMATION

**Voltage**  
220v/30a/1ph

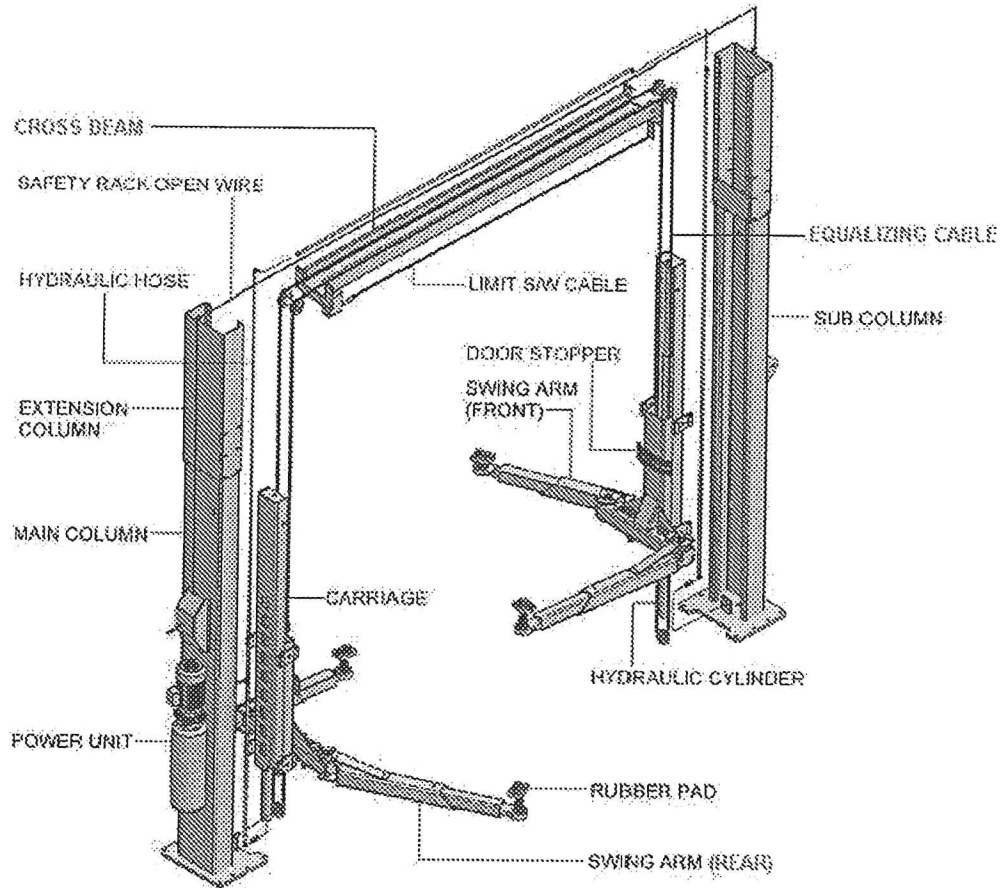

(fig. 2)

### BASIC STRUCTURE OF PRODUCT

(fig. 2)

#### BASIC STRUCTURE OF PRODUCT

This product is a two-post, dual cylinder, "direct drive" lift which uses steel cables for equalization. The main components are the towers, lifting carriages, swing arms, cylinders, cables and power unit. Arms and carriages have locking mechanisms for simple and safe operation.

Depressing the switch on the power unit raises the lift. Releasing the switch stops the lift. Lift should always be settled on the carriage locking mechanisms. To lower the lift, simply raise the carriages up off the locks, pull and hold the "single point release" handle on the main post to disengage the locks, and depress the lowering handle on the power unit.

Arms rotate and telescope for easy use. Adapters are included for raising the height of the basepad at the end of the arm. Swing arm locks automatically engage as the carriages rise, and disengage once they are lowered to the floor. A "cut-off" cable prevents vehicle contact with the overhead beam.

## INSTALLATION

### TOOLS REQUIRED

Rotary Hammer Drill (if unit is to be anchored) Medium Crescent Wrench  
3/4" Masonry Bit (if unit is to be anchored) Medium Pipe Wrench  
Hammer Crow Bar  
4 Foot Level Chalk Line  
Open-End Wrench Set (7/16" to 1-1/8") Medium Flat Screwdriver  
Socket and Ratchet Set (7/16" to 1-1/8") 25' Tape Measure  
Hex-key/Allen Wrench Set Needle Nose Pliers  
Clip-Ring Pliers

### IMPORTANT NOTICE

These instructions must be followed to ensure proper installation and operation of your lift. Failure to comply with these instructions can result in serious bodily harm and void product warranty. Manufacturer will assume no liability for loss or damage of any kind, expressed or implied, resulting from improper installation or use of this product.

## PLEASE READ ENTIRE MANUAL PRIOR TO INSTALLATION.

### STEP 1

(Selecting Site)

Before installing your new lift, check the following:

1. **LIFT LOCATION:** Always use architect's plans when available. Check layout dimension against floor plan requirements making sure that adequate space is available.
2. **OVERHEAD OBSTRUCTIONS:** The area where the lift will be located should be free of overhead obstructions such as heaters, building supports, electrical lines, etc.
3. **DEFECTIVE FLOOR:** Visually inspect the site where the lift is to be installed and check for cracked or defective concrete.

### STEP 2

(Floor Requirements)

Specifications of concrete must be adhered to. Failure to do so could cause lift failure resulting in personal injury or death.

- A. A level floor is suggested for proper installation and level lifting. Small differences in floor slopes may be compensated for by proper shimming. If a floor is of questionable slope, consider a survey of the site and/or the possibility of pouring a new level concrete slab.
  - **DO NOT** install this lift on any asphalt surface or any surface other than concrete.
  - **DO NOT** install this lift on expansion seams or on cracked or defective concrete.
  - **DO NOT** install this lift on a second/elevated floor without first consulting building architect.
  - **DO NOT** install this lift outdoors unless special consideration has been made to protect the power unit from inclement weather conditions.

## CONCRETE SPECIFICATIONS

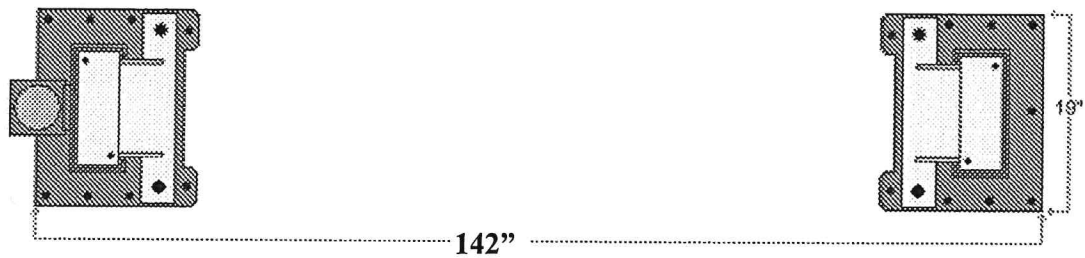

**NOTE:** All models **MUST** be installed on 3,000 PSI reinforced concrete only conforming to the minimum requirements shown above. New concrete must be adequately cured for at least 30

## FLOORPLAN / LAYOUT

### STEP 3

(Positioning Towers)

1. Determine the approach angle for the lift.
2. Determine where the power unit will be located. The POWERSIDE column has the power unit mounting bracket attached to the side.
3. Once location is determined, use a carpenter's chalk line to layout a grid for post locations. Keep all dimensions and square within 1/8" or lift malfunction can occur.
4. After the post locations are properly marked, place posts within chalked outline.  
(Note: **DO NOT** secure both posts at this time.)
5. Double check all dimensions and make sure the layout is square.
6. Stand the columns in place making sure to position the power unit mounting bracket column at the correct location as indicated above.

**CAUTION: Be very careful not to disturb the columns and cross rails at this time as they may tip over and cause personal injury or harm.**

7. Once Main Side Tower (Power Unit Tower) is in final position, secure to the floor using Anchor Bolts. (fig. 3 & fig. 4 below)  
(fig. 3) (fig. 4)
8. Before tightening Anchors, plum & shim towers. (fig. 5 below)



Drill Holes In Concrete  
As Follows

MAKE SURE TO USE  
CORRECT SIZE DRILL-BIT  
AS PER CONCRETE  
BOLT REQUIREMENTS

4-1/2" Deep / 7K - 10K Models  
6" Deep / 12K - 18K Models

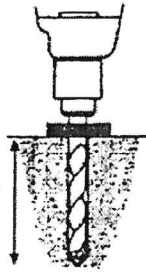

(fig. 3)

Tap anchor bolts into each hole  
with a hammer until the washer  
rests against the baseplate

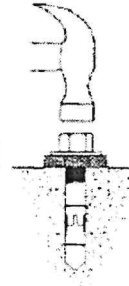

(fig. 4)

8. Before tightening Anchors, plum & shim towers. (fig. 5 below)

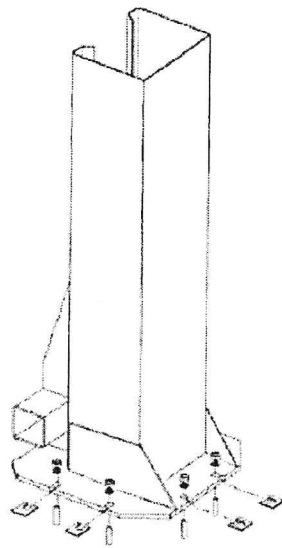

(fig. 5)

9. Tighten Anchor Bolts on Main Side Tower. (fig 6)

**STEP 4**  
(Installing Extensions)

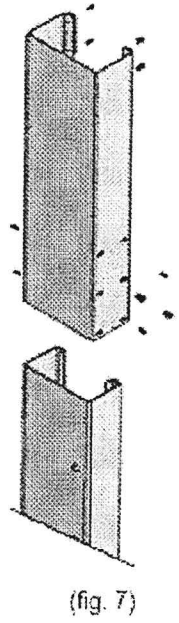

**1. Install Extensions**

**STEP 3**  
(Installing Overhead Beam)

1. Raise **Overhead Beam** into position and secure to Posts using the eight Allen head bolts (4 on each side). (fig. 8)

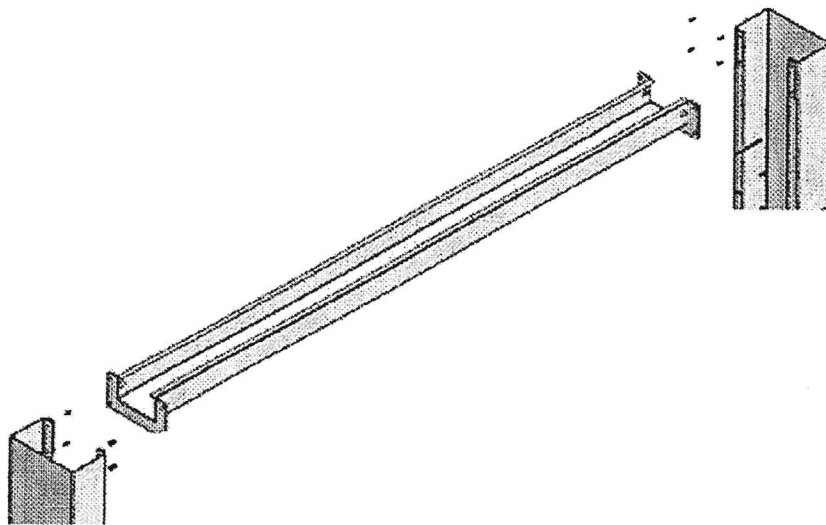

#### STEP 4

(Swing Arm Installation)

1. Install **Swing Arms** onto carriage assemblies at this time. Use clip-ring pliers to remove clip rings on Arm Pins. Remove Pins from Arms, slide Arms onto Carriages, and replace Pins and clip-rings.

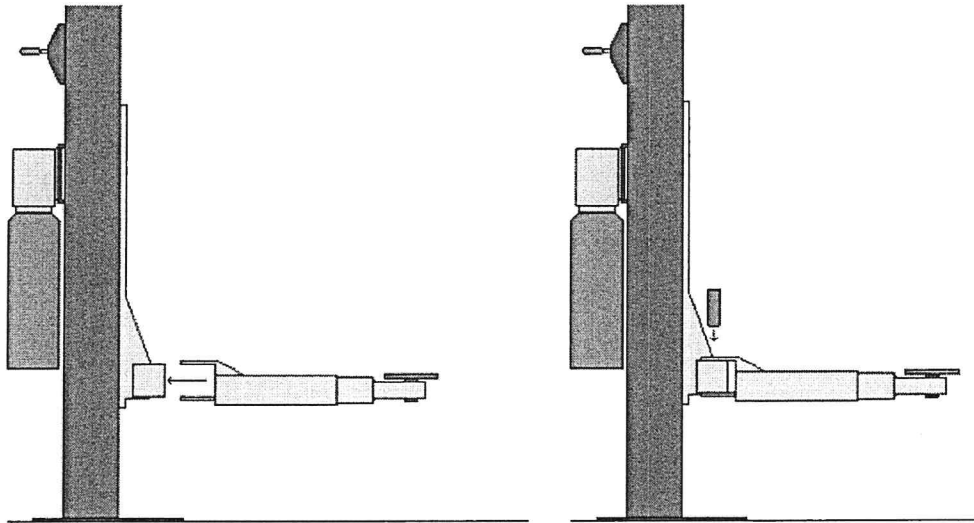

(fig. 9)

#### STEP 5

(Power Unit Installation)

1. Mount the Power Unit to the mounting bracket using the 5/16" x 3/4" hex bolts and nylon nuts, then fill the reservoir with 12 quarts of ISO-32 or AW-32 10-wt. Hydraulic Oil. (Mobile DTE 24 or Texaco HD 32 is also acceptable). (fig. 10)

**WARNING: DO NOT use Dexron ATF in this lift!**

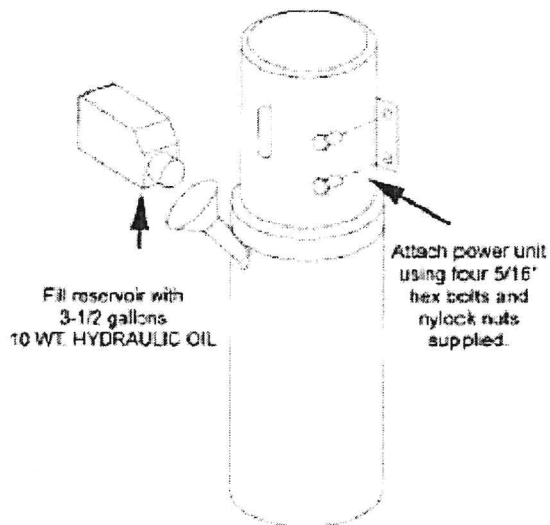

(fig. 10)

2. Install fitting on power unit.

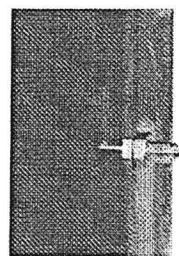

(fig. 11)

### REVISED DESIGN

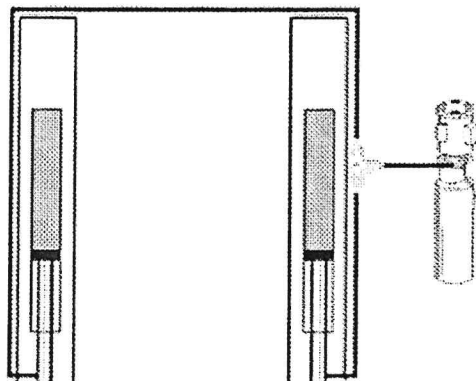

(fig. 12)

3. Connect the Straight End of the Power Unit hose to the Power Unit. Connect Angled End of the Hose to the Fitting on Lift Tower. (fig. 11)
3. Connect Hydraulic Hoses within Towers and run hose through Overhead Beam. Verify all hydraulic connections.
4. Have a certified electrician make the electrical connection. A Twist-Lock plug is recommended for safety purposes.

### STEP 6

(Cable Installation)

1. Raise and lock each carriage approximately 28" above the ground. **WARNING:** Make sure that the safety locks on each column are fully engaged before routing cables or hoses. Carriages **MUST** be equal height from the floor before proceeding.

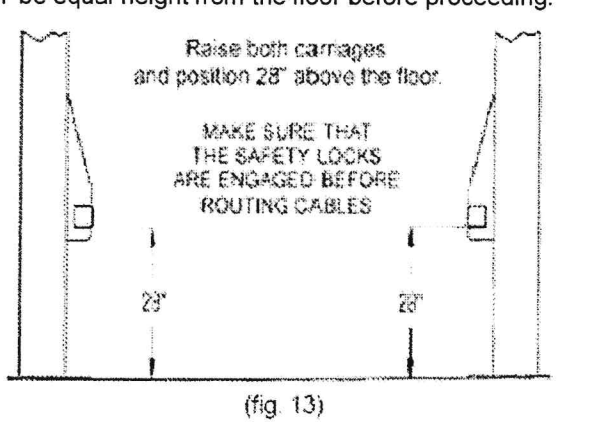

(fig. 13)

2. With the carriages in equal position from the floor, route the equalizer cables as shown. (fig. 14 - 16)
3. With the carriages still in equal position from the floor, tighten cable nuts until slack is removed. Once slack is removed, alternate from side to side (carriage to carriage), tightening each cable equally, so that neither cable is tighter than the other, and so that neither carriage raises off of its safety lock. Tighten until there is approximately an inch of deflection in each cable.

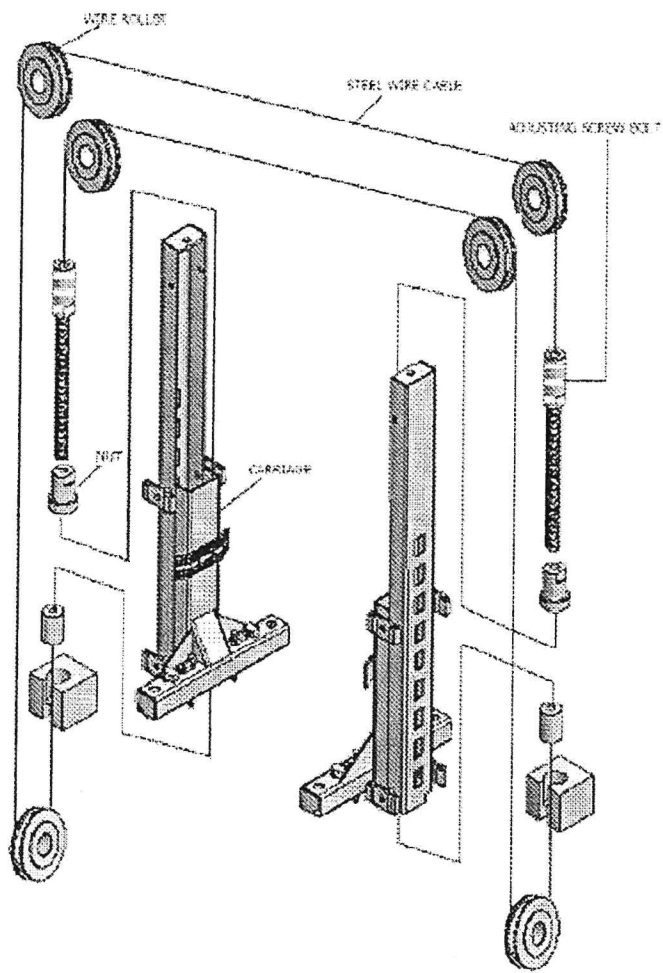

(fig. 14)

**TOP CARRIAGE PLATE**

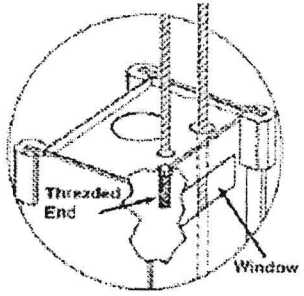

(fig. 15)

**BOTTOM CARRIAGE PLATE**

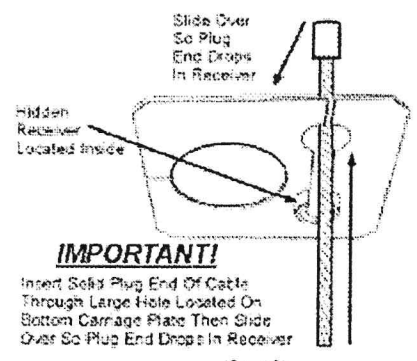

(fig. 16)

**STEP 7**  
(Route Safety Lock Release Cable)

1. Install thin Lock Release Cable on Main Side Tower Locking Mechanism, and route across Overhead Beam, down to Locking Mechanism on Offside Tower. Adjust as necessary and verify operation of Safety Locks.

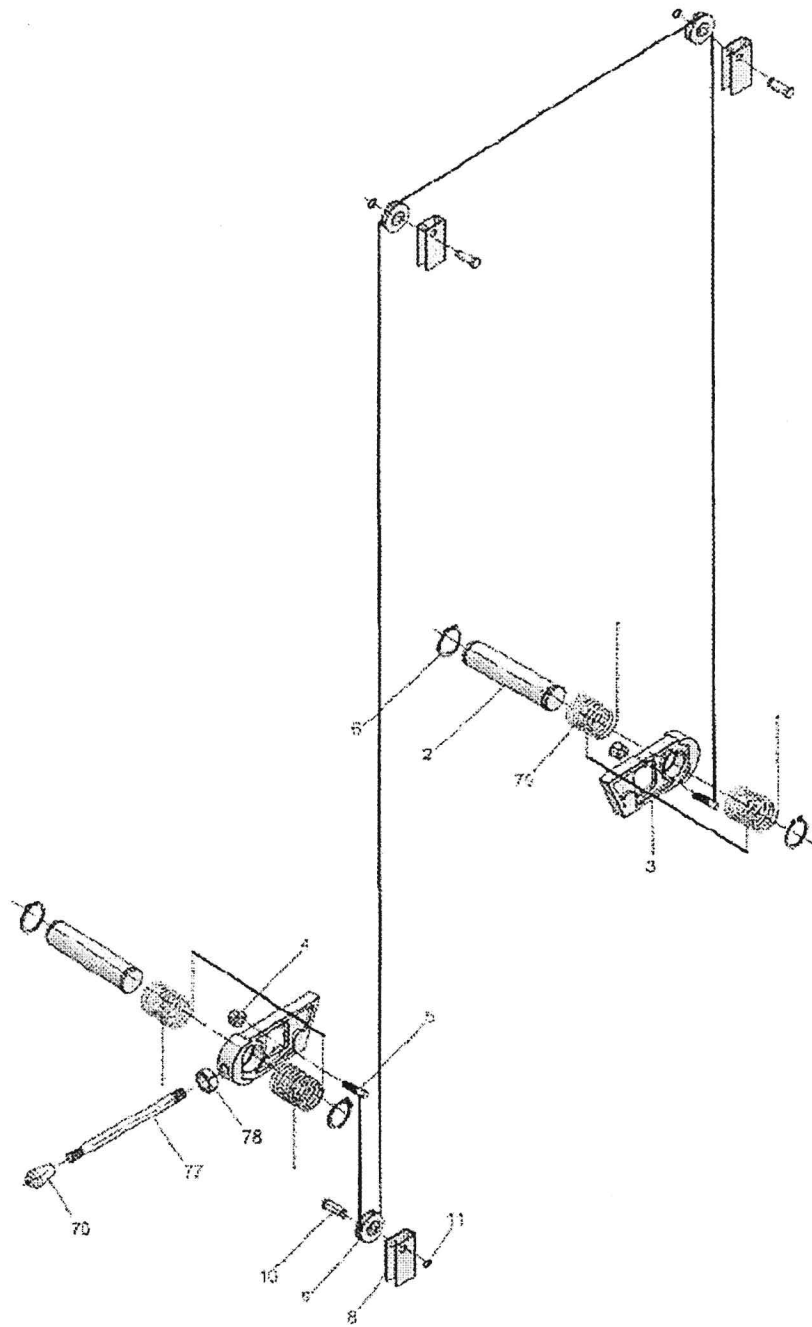

(fig. 17)

### STEP 8

(Secure Off Side Tower)

1. Re-check position of Off Side Tower. Operate lift (see Step 9 below), running it up and down to verify operation. Once operation is verified and all measurements checked, be sure Off Side

Tower is plum and squared off from Main Side Tower. Only when all this is confirmed should the Off Side Tower be secured to the floor.

2. Drill holes and install anchoring bolts as described above for Main Side Tower. Shim as required. Secure Off Side Tower.

#### **STEP 9**

(Start Up)

1. Make sure power unit reservoir is full with 12 quarts of 10-wt Hydraulic Oil.
2. Spray inside of the columns where the slide blocks glide with a light lubricant or WD-40.
3. Press the "UP" Switch on the power unit.
4. The lift will slowly raise.

#### **IF LIFT DOES NOT RAISE:**

CHECK hose connections. Fluid should be pumping through the hose connected to the Power Unit.

CHECK fluid level.

CHECK electrical connection.

Contact factory.

**Note:** There will be some initial stretching of the cables in the beginning. It will be necessary to readjust the cables a week after first use, then every six months thereafter.

Run the lift up and down a few times to ensure that the locks are engaging uniformly and that the safety release mechanisms are functioning properly. Re-adjust if necessary.

**CAUTION:** When lowering the lift PAY CAREFUL ATTENTION. ALWAYS make sure that ALL LOCKS are disengaged. If one of the locks inadvertently locks on descent the lift and/or vehicle may disrupt causing personal injury or death.

#### **STEP 10**

(Install Cut-Off Cable)

1. Using appropriate hardware, fasten mounting brackets to overhead beam on either tower. Make sure to secure switch box to the Main Side tower. (Fig. 18)
2. Attach red limit wire to Main Side switch box. Attach other end of red limit wire to the bracket on the Off Side tower.
3. Using pre-installed wire, wire switch to power unit. (Fig. 19)
4. Adjust red limit wire until no more than 1" of movement shuts off power unit.

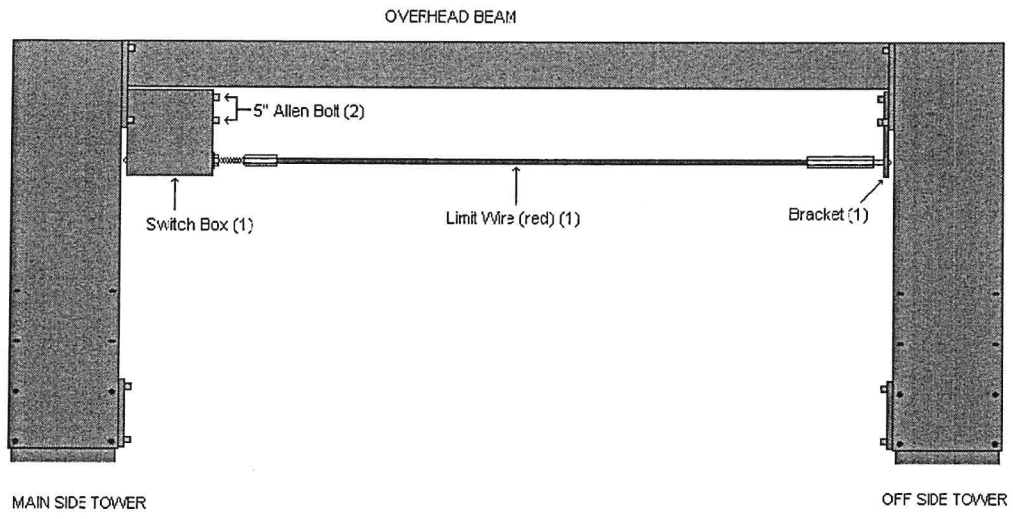

(fig. 18)



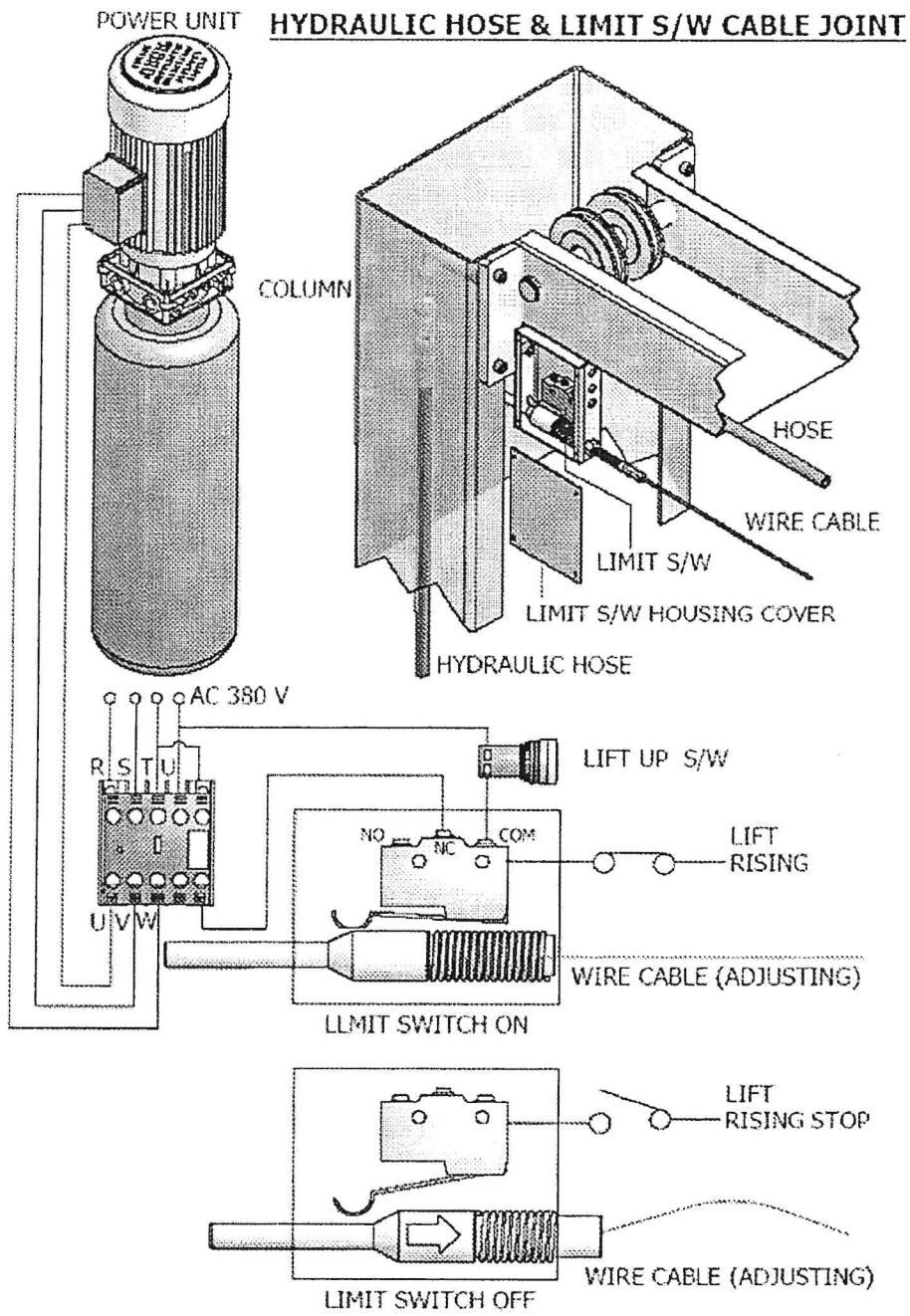

**IMPORTANT INSTRUCTIONS  
PLEASE READ  
OPERATION**

1. Position vehicle in the center of lift, evenly between columns. (Fig. 20 & 21)

2. Position Arm Pads beneath vehicle Lifting Points. Be sure weight is distributed equally on all four arms.
3. Before raising vehicle, be sure all personnel are clear of the lift. Pay careful attention to any overhead obstructions.
4. Raise vehicle to the desired working height.
5. Lower lift onto nearest safety lock to support load. NEVER ALLOW LOAD TO REMAIN UNSUPPORTED BY THE SAFETY LOCKS.
6. Do not permit the cables to go slack.

**TO LOWER THE LIFT**

1. First, raise the lift to clear all the safety locks.
2. Disengage safety locks.
3. Push the lowering handle and hold until the lift has descended completely.
4. If the lift is shaking, vibrating or swaying, reduce the descending speed.

**WEEKLY MAINTENANCE**

1. Lubricate all rollers with general purpose lubricating oil.
2. Check all connections, bolts, and pins to ensure proper mounting.
3. Lubricate primary safety pivot pin with general purpose lubricating oil
4. Adjust all cable tensions after first week. (Check every six months thereafter.)

**MONTHLY MAINTENANCE**

1. Check safeties, making sure they are in good operating condition.
2. Inspect all anchor bolts and tighten as necessary.
3. Make a visual inspection of all moving parts for wear.

If worn parts are evident DO NOT USE LIFT.

Replace all worn parts before lift is put back into operation.

**!!!WARNING!!!**

1. If any component of the lift is found to be defective, DO NOT USE LIFT!
2. Never operate the lift with any person or equipment below.
3. Always stand clear of lift when raising or lowering.
4. Never exceed rated capacity.
5. Always ensure safeties are engaged before any attempt is made to work on or near vehicle.
6. Never leave lift in an elevated position unless it is settled firmly upon the safety locks.

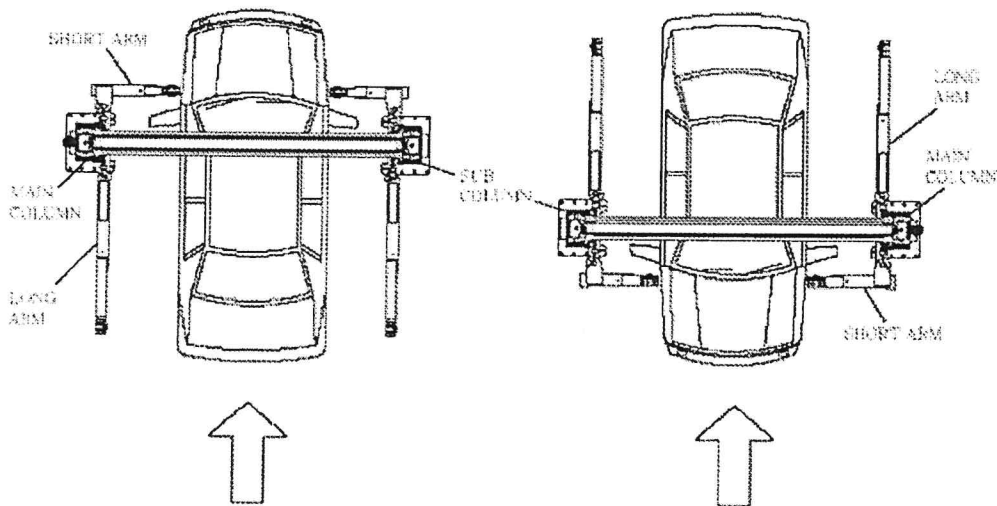

(fig. 20)

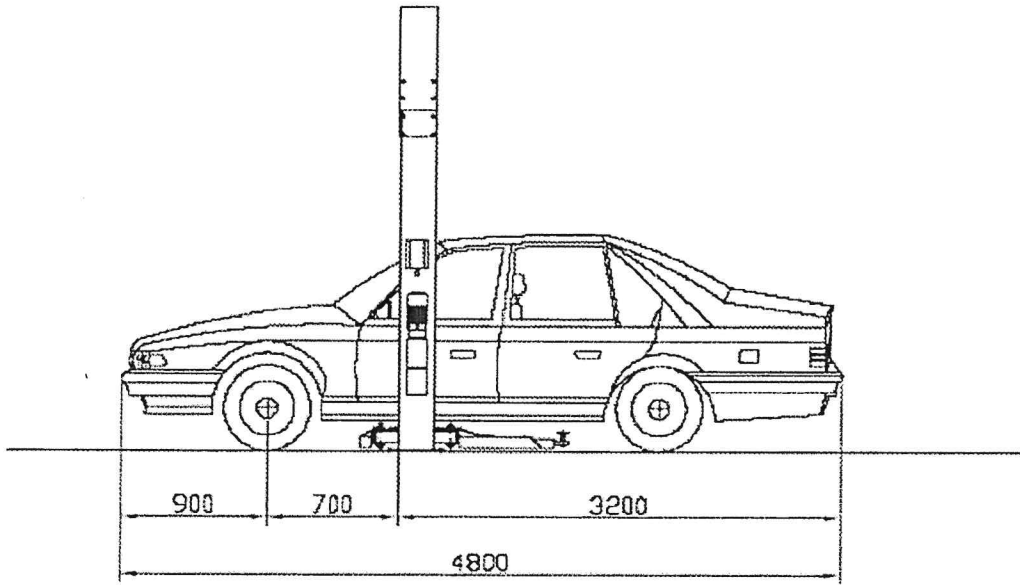

(fig. 21)

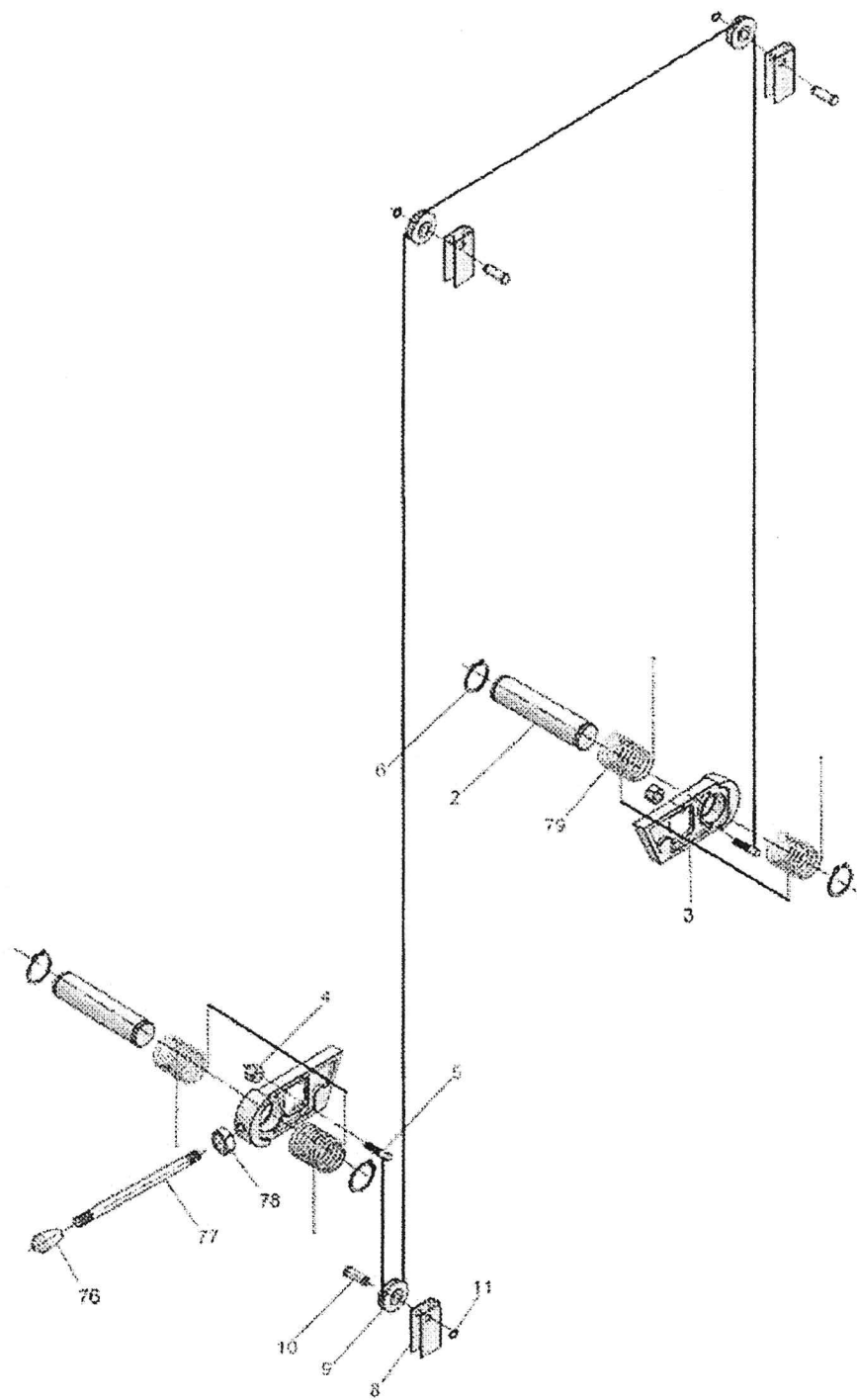

Safety Lock Release

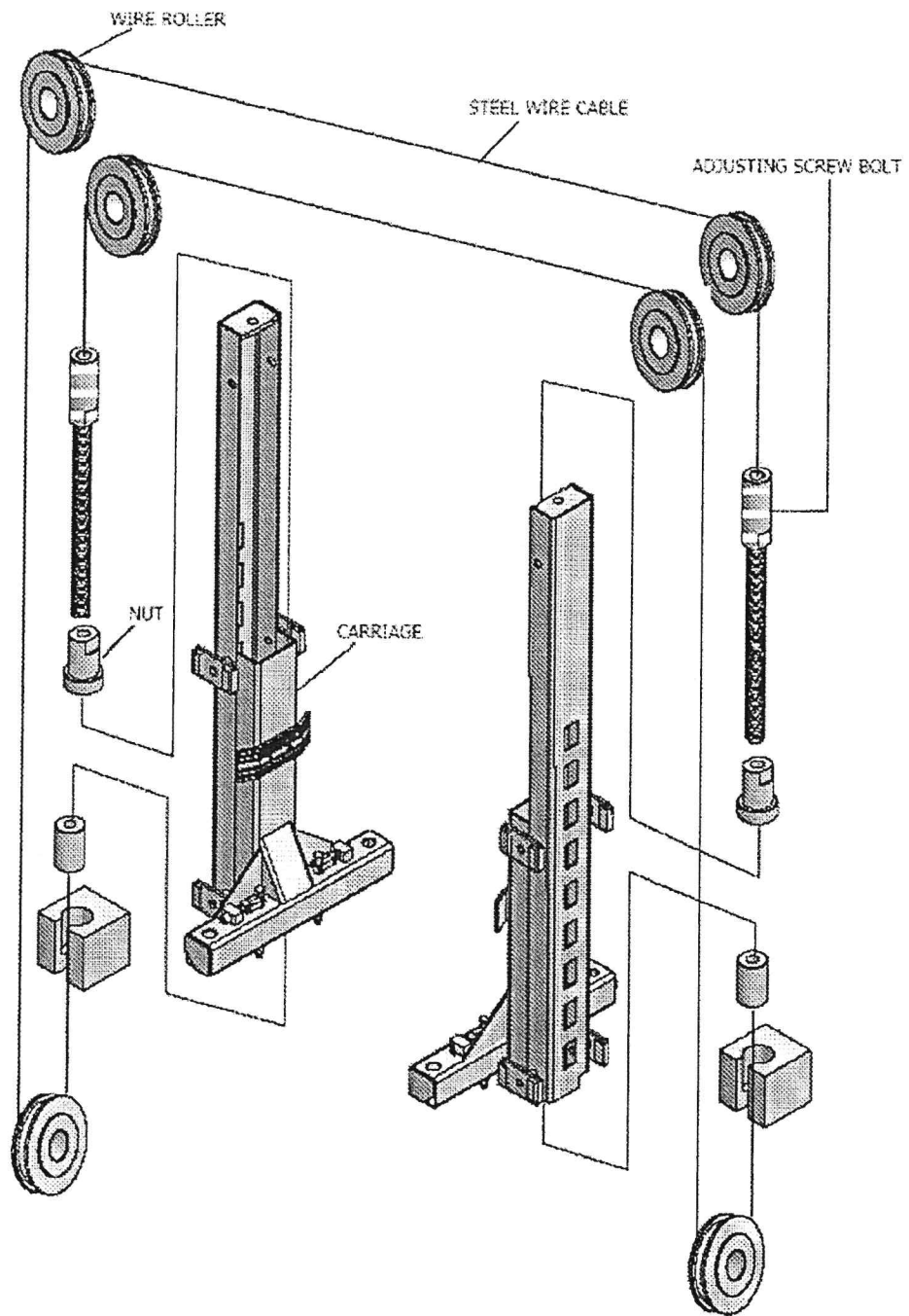

Equalizing Cable Routing